

TECHNICAL FEATURES and FUNCTIONS

1. DIMENSIONS

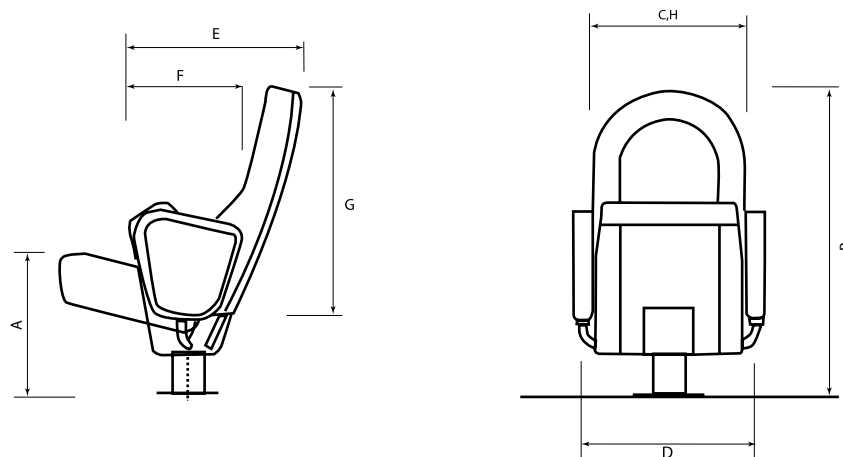

Tondo Flex

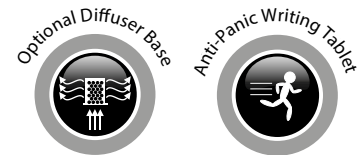

Dimensions (cm)	Overall width D	Total depth E	Total height B	Seat height A	Seat width C	Seat depth F#	Backrest height G	Backrest width H	Weight (kg)
Tondo Standard	52 - 58	75	99	44	47	45	70	50	26,5
Tondo Flex	52 - 58	54 - 75	99	44	47	45	70	50	26,5

According to DIN norms, up to the lumbar support point

2. MATERIALS

2.1. Construction

The seat and backrest carrier metals are welded to the central leg. The seat is mounted on the floor from 4 points on the single metal foot in the center.

2.2. Backrest

It is produced from injection polyurethane in a form suitable for back ergonomics. The back board made of beech wood is combined with cold foam and completely fabric is laid.

2.3. Seat

It is produced from injection polyurethane in a form suitable for ergonomics. The seat board made of beech wood is combined with cold foam and completely fabric is upholstered.

2.4. Metal Parts

Metal parts are electrostatic powder paint black (RAL 9005).

2.5. Foaming Parts

It is injection polyurethane and does not contain CFCs (chlorofluorocarbons).

Density: 59 kg/m³ +/- 3
Seat foam thickness: 52 mm
Backrest foam thickness: 51 mm

3. OPTIONS

3.1. Armrest Types

Standard: Armrest with foam and fabric upholstery on wooden frame.

Flex (PU armrest): Hollow or upholstered with a 25 mm thick polyurethane frame.

Flex (Armrest with Writing Tablet): Foam and fabric fully upholstered on MDF coated metal carcass.

Armrest lower covers: It is made of sheet metal to hide the armrest carrier pipe, which can be used optionally in PU and headrest armrests with writing tablets.

3.2. Cup Holder

Made of reinforced polyamide. It is approximately ø140 mm in diameter and is mounted on the front of the armrest with screws.

3.3. Fabric

Non-flammable fabric types for safety available.

3.4. Embroidery (Optional)

The maximum dimensions for the logo can be made at 7 cm width, and the width-length is measured in direct proportion. 100% polyester thread is used for embroidery. It can be applied to the desired area on

the front or back, depending on the backrest model. A separate embroidery work is done for each logo. The yarn color closest to the logo color is selected. There is no restriction on the number of colors.

3.5. Other Options

- Different armrest options for optional different axis distances
- Optional wood veneer on armrest
- Normal or Antipanic foldable wooden writing tablet (Beech plywood, MDF - Lacquered veneer, MDF - Natural veneer)
- Optional diffuser base
- Optional cup holder, seat row numbers and aisle lighting fixture
- Foldable seat (Tondo Flex model)
- Ergonomically designed freon-free seat and backrest foam
- Adjustable backrest angle during assembly
- Four-point floor mounting
- Different axis distances applicable according to the projects.
- Possibility of installation in radial, angled and flat halls.

4. TECHNICAL RULES, TESTS AND QUALITY APPROVALS

- ISO 9001 certified.
- It is TS EN 12727 certified.