

## TECHNICAL FEATURES and FUNCTIONS

### 1. DIMENSIONS

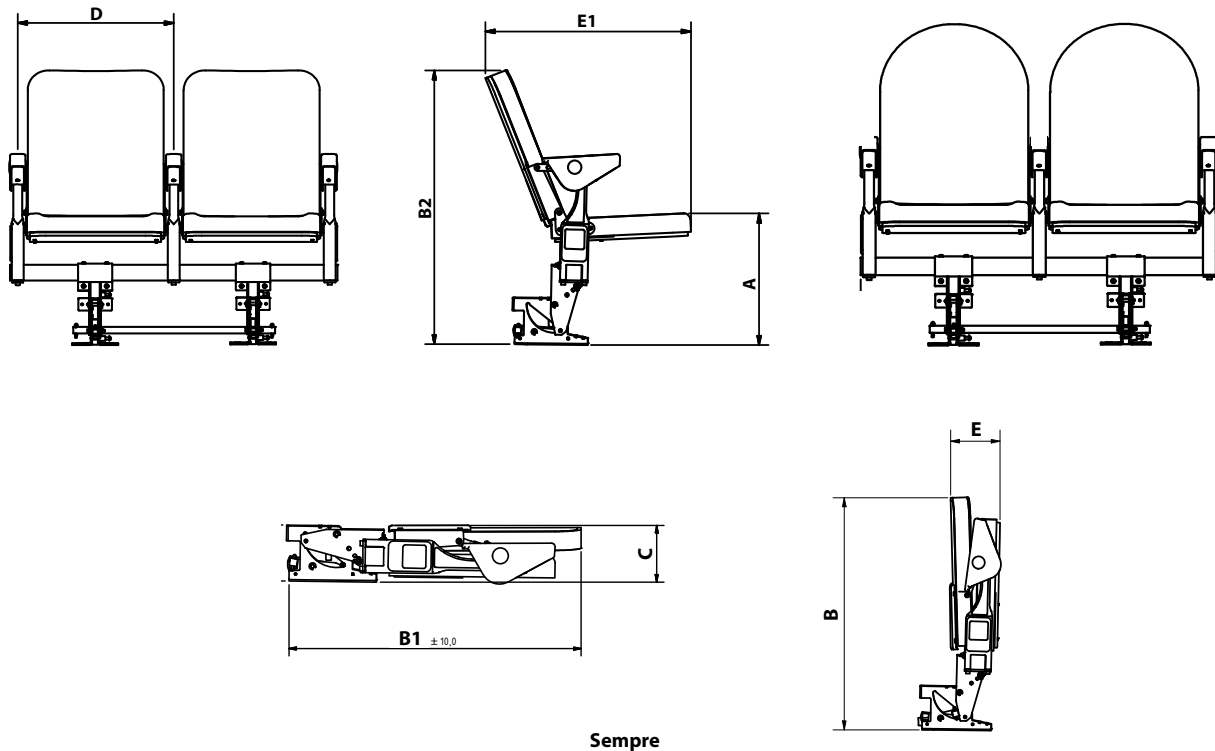

Sempre

Dimensions (cm)	Overall width D	Total depth E # - E1	Total height B - B1 - B2	Seat height A	Tilt height C	Weight (kg)
<b>Sempre</b>	50	15 - 66	85 - 88 - 91	42	18	22

# When the seat and backrest are made of outer wood, the depth increases by 1 cm.

## 2. MATERIALS

### 2.1. Construction

Feet with damper braking for telescopic feature. Aluminum armrests with profile busbar connection. Metal connection group that provides the connection of the seat and backrest to the aluminum armrests and at the same time works integrated with each other.

### 2.2. Backrest

It is produced from injection polyurethane in a form suitable for back ergonomics. The back board made of beech wood is combined with cold foam and completely fabric is laid. Thanks to its zippered fabric upholstery feature, it provides a quick change opportunity.

### 2.3. Seat

It is produced from injection polyurethane in a form suitable for ergonomics. The seat board made of beech wood is combined with cold foam and completely fabric is upholstered. The seat can be folded. Thanks to its zippered fabric upholstery feature, it provides a quick change opportunity.

### 2.4. Metal Parts

Metal parts are electrostatic powder paint black (RAL 9005).

### 2.5. Foaming Parts

It is injection polyurethane and does not contain CFCs (chlorofluorocarbons).

Density: 57 kg/m<sup>3</sup> +/- 3  
Seat foam thickness: 40 mm  
Backrest foam thickness: 50 mm

### 2.5. Telescopic Tribune Feature

Telescopic tribune is a solution that allows flexible management of a venue. It can be adjusted according to the activity needs with its system consisting of retractable rows of different heights. The fixed telescopic grandstand is attached to the floor and the wall, while the fully movable one provides more configuration. According to its attached size, it can be divided into independent modules with its own driver, making it easy to store when not in use.

## 3. OPTIONS

### 3.1. Armrest Types

**Standard Armrest:** Aluminum die-cast armrest. Polyurethane armrest pad.

- Solid wood or plywood armrest top wood.
- Oval or rectangular backrest option.
- Seat and backrest plywood exterior wood option.

### 3.2. Fabric

In addition to the available fabric options, there are non-flammable fabric types for safety.

### 3.3. Other Options

- There are 5 color options available as wenge, mahogany, walnut, cherry and natural. If desired, different colors can be applied optionally. - Seat row numbers and corridor lighting fixture

### 3.4. Embroidery (Optional)

The maximum dimensions for the logo can be made at 7 cm width, and the width-length is measured in direct proportion. 100% polyester thread is used for embroidery. It can be applied to the desired area on the front or back, depending on the backrest model. A separate embroidery work is done for each logo. The yarn color closest to the logo color is selected. There is no restriction on the number of colors.

## 4. TECHNICAL RULES, TESTS AND QUALITY APPROVALS

- ISO 9001 certified.
- It is TS EN 12727 certified.