

TECHNICAL FEATURES and FUNCTIONS

1. DIMENSIONS

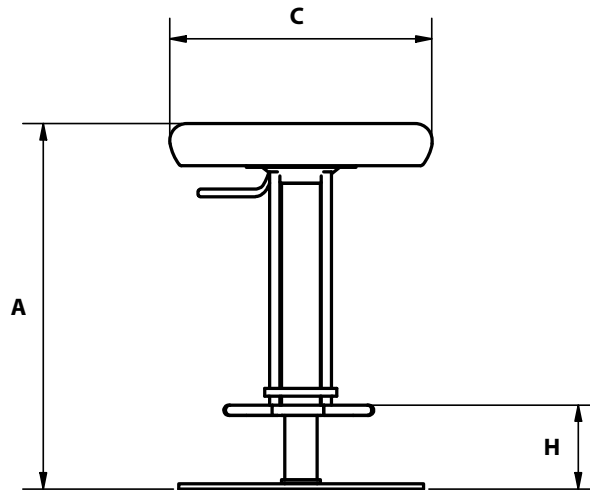

James

Dimensions (cm)	Seat width C	Seat height A	Footrest height H	Weight (kg)
James	40	57 - 76	17 - 36	12

2. MATERIALS

2.1. Construction

Metal footrest circle and swivel seat sheet are mounted on the interlocking pipe and gas lift group on the circular floor plate that provides a balanced stance.

2.2. Seat

15mm. thick beech plywood seat wood covered with foam and fully furnished with fabric.

2.3. Metal Parts

Metal parts are produced as chrome plated.

3. TECHNICAL RULES, TESTS AND QUALITY APPROVALS

- ISO 9001 certified.